

Agilent Technologies N4421B Option H67

User's and Service Guide

Use this manual with the following documents:

PNA Series Network Analyzer On-line Help System



Agilent Technologies

Manufacturing Part Number: N4421-90001

Printed in USA

March 2007

© Copyright 2006, 2007 Agilent Technologies, Inc. All rights reserved.

Warranty Statement

THE MATERIAL CONTAINED IN THIS DOCUMENT IS PROVIDED “AS IS,” AND IS SUBJECT TO BEING CHANGED, WITHOUT NOTICE, IN FUTURE EDITIONS. FURTHER, TO THE MAXIMUM EXTENT PERMITTED BY APPLICABLE LAW, AGILENT DISCLAIMS ALL WARRANTIES, EITHER EXPRESS OR IMPLIED WITH REGARD TO THIS MANUAL AND ANY INFORMATION CONTAINED HEREIN, INCLUDING BUT NOT LIMITED TO THE IMPLIED WARRANTIES OF MERCHANTABILITY AND FITNESS FOR A PARTICULAR PURPOSE. AGILENT SHALL NOT BE LIABLE FOR ERRORS OR FOR INCIDENTAL OR CONSEQUENTIAL DAMAGES IN CONNECTION WITH THE FURNISHING, USE, OR PERFORMANCE OF THIS DOCUMENT OR ANY INFORMATION CONTAINED HEREIN. SHOULD AGILENT AND THE USER HAVE A SEPARATE WRITTEN AGREEMENT WITH WARRANTY TERMS COVERING THE MATERIAL IN THIS DOCUMENT THAT CONFLICT WITH THESE TERMS, THE WARRANTY TERMS IN THE SEPARATE AGREEMENT WILL CONTROL.

DFARS/Restricted Rights Notice

If software is for use in the performance of a U.S. Government prime contract or subcontract, Software is delivered and licensed as “Commercial computer software” as defined in DFAR 252.227-7014 (June 1995), or as a “commercial item” as defined in FAR 2.101(a) or as “Restricted computer software” as defined in FAR 52.227-19 (June 1987) or any equivalent agency regulation or contract clause. Use, duplication or disclosure of Software is subject to Agilent Technologies’ standard commercial license terms, and non-DOD Departments and Agencies of the U.S. Government will receive no greater than Restricted Rights as defined in FAR 52.227-19(c)(1-2) (June 1987). U.S. Government users will receive no greater than Limited Rights as defined in FAR 52.227-14 (June 1987) or DFAR 252.227-7015 (b)(2) (November 1995), as applicable in any technical data.

Safety Notes

The following safety notes are used throughout this document. Familiarize yourself with each of these notes and its meaning before performing any of the procedures in this document.

WARNING	Warning denotes a hazard. It calls attention to a procedure which, if not correctly performed or adhered to, could result in injury or loss of life. Do not proceed beyond a warning note until the indicated conditions are fully understood and met.
----------------	---

CAUTION	Caution denotes a hazard. It calls attention to a procedure that, if not correctly performed or adhered to, could result in damage to or destruction of the instrument. Do not proceed beyond a caution sign until the indicated conditions are fully understood and met.
----------------	---

Statement of Compliance

This product has been designed and tested in accordance with the standards listed on the Manufacturer's Declaration of Conformity, and has been supplied in a safe condition. The documentation contains information and warnings that must be followed by the user to ensure safe operation and to maintain the product in a safe condition.

Definitions

- *Specifications* describe the performance of parameters covered by the product warranty (temperature – 0 to 55 °C, unless otherwise noted.)
- *Typical* describes additional product performance information that is not covered by the product warranty. It is performance beyond specification that 80% of the units exhibit with a 95% confidence level over the temperature range 20 to 30 °C. Typical performance does not include measurement uncertainty.
- *Nominal* values indicate expected performance, or describe product performance that is useful in the application of the product, but is not covered by the product warranty.

Contents

General Information

Description	2
Content List	2
General Specifications	3
Power Requirements	3
Dimensions and Space Requirements	4
Maximum Power Levels	5
Operation	6
N4421BH67 Multiport Test Set	7
Test Set Status LEDs	7
Port 2 and Access Ports – SMA (female)	7
Port 4 and Access Ports – SMA (female)	7
Test Ports – 1.85 mm Bulkhead Test Ports (female)	8
Line Switch	8
Line Module	8
Available Fuses	9
System Setup	10
Attaching the Test Set to the PNA	10
Preparing the Network Analyzer	10
RF Cable Connections	12
Firmware Revision Verification	14
Enabling 4-Port Capability	14
Specification	17
Operator Check and Performance Verification	18
Overview	18
Equipment Required	18
Procedure	19
Declaration of Conformity	27
Block Diagram	28
Servicing the N4421BH67 Multiport Test Set	29
Replaceable Parts	29
Shipping Instructions	30
Safety and Regulatory Information	31
Introduction	31
Before Applying Power	31
Connector Care and Cleaning	31
Compliance with Canadian EMC Requirements	31
Complies with European EMC Directive 89/336/EEC, amended by 93/68/EEC	31
Complies with European Low Voltage Directive 73/23/EEC, amended by 93/68/EEC	31
Compliance with German Noise Requirements	32
Warnings	32
Cautions	33
Instrument Markings	34
Contacting Agilent Sales and Service Offices	35

General Information

Description

The [Agilent Technologies N4421B Option H67](#) is a 10 MHz to 67 GHz S-parameter Test Set for use with the E8361A Option 014/550 providing 4-port error corrective measurement capability.

E8361A Performance Network Analyzer information, data sheets, white papers, or manuals can be viewed or printed by visiting <http://www.agilent.com/find/pna>.

Agilent does not supply accessories, such as the test port cables and DUT control cables with the N4421BH67.

Content List

Agilent Part Number	Description	Qty
5023-0132	Locking Feet	1
AW00268	Label "Port 3" ¹	1
N4421-20009	Long Interconnect RF Access Jumpers	4
N4421-20010	Short Interconnect RF Access Jumpers	4
N4421-90001	User's and Service Guide	1

1. Place the label "Port 3" above the PNA Port 2 silk-screen. Port 2 on the PNA is referenced as Port 3 throughout the N4421BH67 User's and Service Guide. Continue to use it as Port 2 when using the PNA as a standalone instrument.

General Specifications

Power Requirements

Verify that the required ac power is available at all necessary locations before installing the Test Set to the PNA.

- Three-wire power cables (which provide a safety ground) must be used with all instruments.
- Air conditioning equipment (or other motor-operated equipment) should not be placed on the same ac line that powers the Test Set and PNA.
- [Table 1](#) contains the maximum VA rating and BTU/hour rating for the instrument. This table can be used to determine the electrical and cooling requirements.

Line power (single phase)

100/120/220/240V 50/60Hz
40 Watts maximum

NOTE Values are based on 120 Vac supplied to the instrument at 60 Hz.

Table 1 Power Requirements

Standard Equipment		
Instrument	Maximum VA Rating	Maximum BTU/Hour
N4421BH67	80	274

Dimensions and Space Requirements

Standard installation of the N4421BH67 and PNA includes configuration and installation on a customer-provided lab bench or table top of adequate size and strength. Refer to [Table 2](#) and [Table 3](#).

Table 2 System Dimensions

Item	Weight
Required Bench Top Dimension:	
Clearance above the bench	43 cm (17 in)
Width	127 cm (50 in)
Depth	102 cm (40 in)
Weight	55 kg (110 lb)

Table 3 Instrument Dimensions

Model	Weight	Height	Width	Depth
N4421BH67	11.8kg (26lb)	13.5 cm (5.25 in)	43.5 cm (17.1 in)	47.0 cm (18.5 in)
E8361A	29 kg (64 lb)	28.0 cm (11.0 in)	43.5 cm (17.1 in)	47.0 cm (18.5 in)
Total	40.8 kg (90 lb)	41.5 cm (16.25 in)	43.5 cm (17.1 in)	47.0 cm (18.5 in)

Maximum Power Levels

CAUTION It is recommend that you do not operate components near damage or maximum levels. The power levels should be kept at less than 3 dB, preferably 6 dB, below damage and maximum level to ensure no damage. See [Table 4](#).

Table 4 Power Levels

Test Setup	Power Level
Maximum N4421BH67 RF Power Levels for Access and Test Ports:	
SOURCE OUT	+15 dbm/20 Vdc
CPLR THRU	+15 dbm/20 Vdc
CPLR ARM	+15 dbm/20 Vdc
A IN	+15 dbm/20 Vdc
B IN	+15 dbm/20 Vdc
PORT 2 and PORT 4	+15 dbm/20 Vdc

NOTE Refer to your PNA specifications to determine the Maximum Input Power Levels for the Access and Test Ports.

NOTE Refer to your PNA specifications to optimize the power levels in the receivers.

NOTE Damage and maximum levels are not necessarily the optimum level.

Operation

This section will describe how to setup and operate the [Agilent Technologies N4421B Option H67](#) with the E8361A 2-Port.

The N4421B Option H67 can be configured for many applications. Included in this document are two typical configurations:

- Agilent N4421BH67 Shipped Configuration, see [Figure 1 on page 7](#).
- Agilent N4421BH67 Setup Configuration, see [Figure 8 on page 13](#).

NOTE The internal firmware of the Agilent E8361A 2-Port PNA must have firmware revision A.06.01.05 or greater.

Power levels may differ from those indicated on the PNA when the Test Set is connected.

N4421BH67 Multiport Test Set

Figure 1 Front Panel (Multiport Test Set)

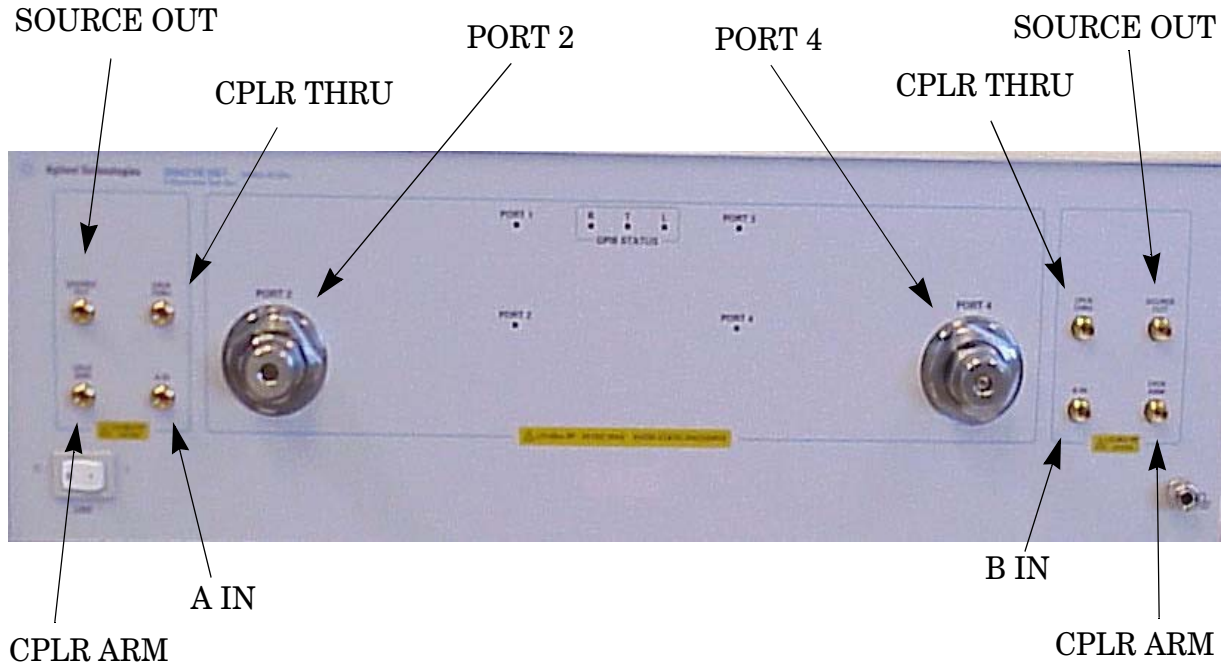

Test Set Status LEDs

PORT 1 – On = Port 1 (located on the PNA) is the source.

PORT 2 – On = Port 2 (located on the Test Set) is the source.

PORT 3 – On = Port 3 (located on the PNA) is the source. (aka. Port 2)

PORT 4 – On = Port 4 (located on the Test Set) is the source.

Port 2 and Access Ports – SMA (female)

SOURCE OUT – Test Port 1 Source Output from PNA.

CPLR THRU – Source Output to PNA Port 1 from the Test Set switch.

CPLR ARM – A Channel Input from the PNA Port 1.

A IN – A Channel Output from the Test Set.

Port 4 and Access Ports – SMA (female)

SOURCE OUT – Test Port 3 Source Output from the PNA.

CPLR THRU – Source Output to PNA Port 3 from the Test Set switch.

CPLR ARM – B Channel Input from PNA Port 3.

B IN – B Channel Output from the Test Set.

Test Ports – 1.85 mm Bulkhead Test Ports (female)

Line Switch

0 – OFF

1 – ON, Power LED On

Figure 2 Rear Panel (Multiport Test Set)



Line Module

Line Module

The line fuse, as well as a spare, reside within the line module. Refer to [Figure 2](#). [Figure 3 on page 9](#) illustrates where the fuses are located and how to access them.

Available Fuses

- **United States (115 V orientation)**
Fuse (F 2.5 A/250V, 2110-1334) U.L. listed and CSA certified
- **Europe (230 V orientation)**
Fuse (F 2.5 A/250V, 2110-1334) IEC listed and U.L. recognized certified

WARNING For continued protection against fire hazard replace line fuse only with same type and rating:

- United States—F 2.5A/250V, Part Number 2110-1334
- Europe—F 2.5A/250V, Part Number 2110-1334

The use of other fuses or material is prohibited.

Figure 3 Line Fuse



System Setup

Attaching the Test Set to the PNA

This step is not necessary if you plan to place the network analyzer and test set in an equipment rack.

Preparing the Network Analyzer

1. Remove the bottom feet from the bottom of the network analyzer. Refer to [Figure 4](#).
2. Remove the lower rear feet and screws (0515-1619) from the rear panel on the network analyzer. Refer to [Figure 4](#).

Figure 4 Rear and Bottom Feet

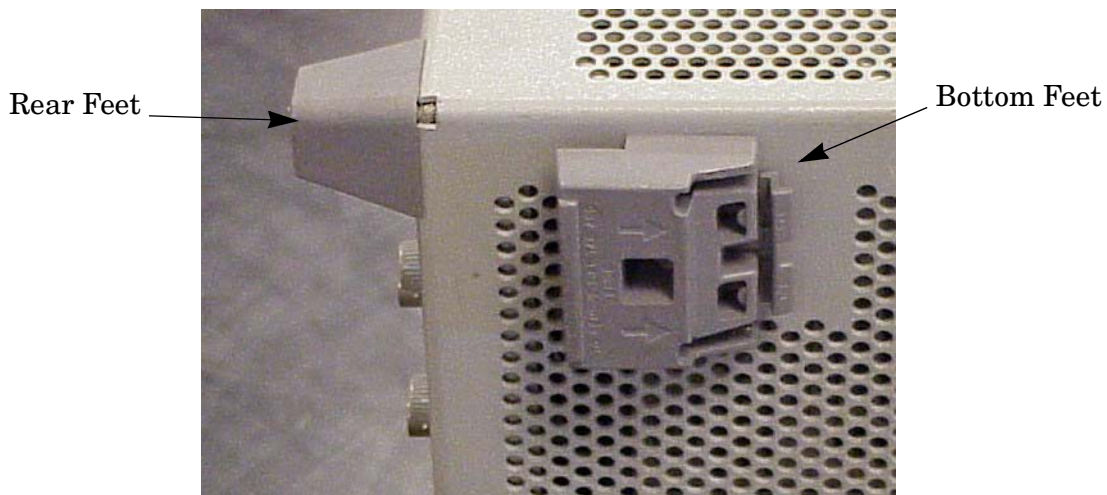

3. Install the two rear locking feet (5023-0132) using screws (0515-1619), where the rear feet were removed. Refer to [Figure 5](#).

Figure 5 Installing Lock Feet

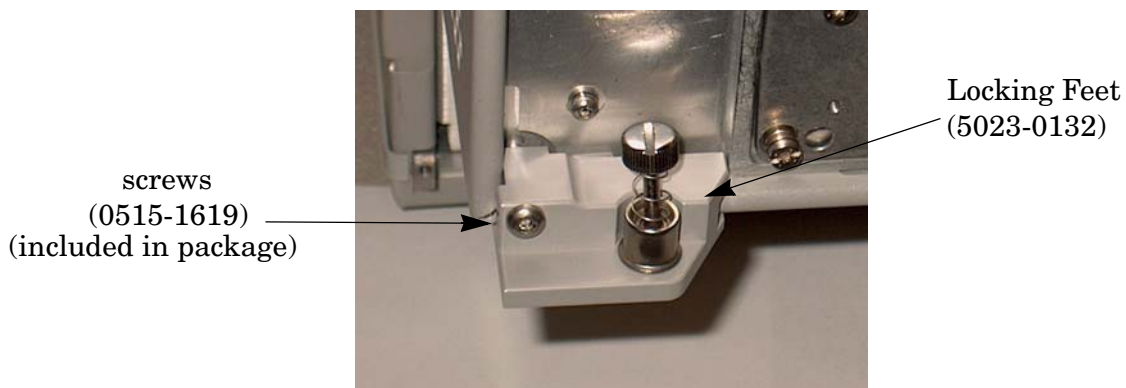

- Place the network analyzer on top of the test set and ensure that the front frame of the network analyzer is positioned slightly forward of the locks that are attached to the test set. Slide the network analyzer back so the locks engage the front frame of the analyzer. Refer to [Figure 6](#).

Figure 6 Locking the Analyzer's

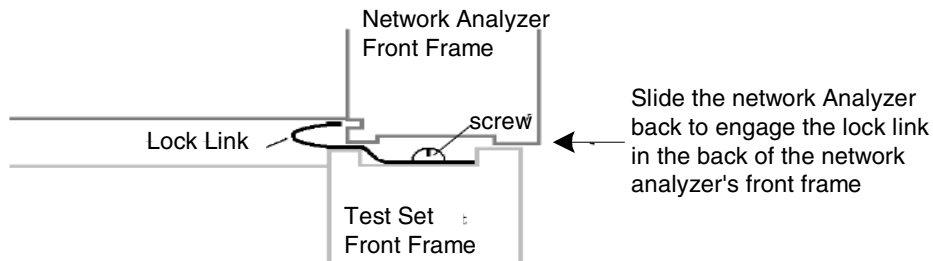

- Secure the network analyzer's lower locking feet to the test set upper locking feet, using the spring-loaded screws on the locking feet. Refer to [Figure 7](#). If the network analyzer's lower locking feet are not aligned with the screw holes in the test set's upper locking feet, loosen the screws securing the feet to the instrument slightly to align.

Figure 7 Locking Feet Screws



RF Cable Connections

Figure 8 on page 13 illustrates the setup configuration of the N4421BH67 Multiport Test Set and how it should be configured to the E8361A 2-Port PNA for normal use.

1. The RF cables supplied with this option connect from the E8361A 2-Port PNA to the N4421BH67 Test Set. Torque each cable to 8 in-lb. Connect the cables as listed in Table 5.
2. Connect the GPIB cable from the PNA to the Test Set. Refer to Figure 8 on page 13.

CAUTION Over-torque will cause damage to the Test Set and may cause connectors to spin or become loose.

Table 5 Cable Connection

RF Cables	From (PNA)	To (Test Set)
N4421-20010	Port 1 SOURCE OUT	Port 2 SOURCE OUT
N4421-20010	Port 1 CPLR THRU	Port 2 CPLR THRU
N4421-20009	Port 1 CPLR ARM	Port 2 CPLR ARM
N4421-20009	Port 1 RCVR A IN	Port 2 A IN
N4421-20010	Port 3 SOURCE OUT	Port 4 SOURCE OUT
N4421-20010	Port 3 CPLR THRU	Port 4 CPLR THRU
N4421-20009	Port 3 CPLR ARM	Port 4 CPLR ARM
N4421-20009	Port 3 RCVR B IN	Port 4 B IN

Figure 8 N4421BH67 Setup Configuration

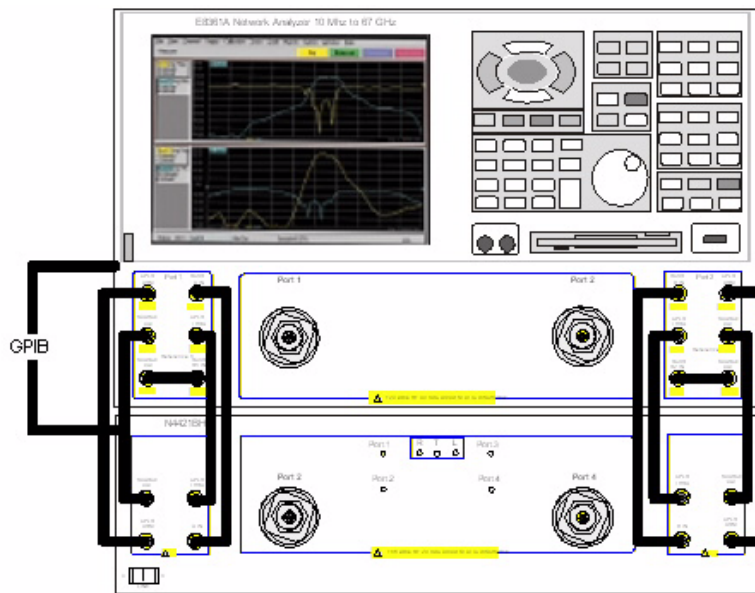

Firmware Revision Verification

To correctly use the N4421BH67 with the PNA, it is necessary to insure that the correct firmware is installed in the PNA. The following steps will guide the user to verify and/or load the latest revision of firmware.

1. Verify PNA firmware is A.06.01.05 or greater.
2. If not, navigate to <http://na.tm.agilent.com/pna/firmware> to download the latest firmware.

Enabling 4-Port Capability

The following steps enable the PNA to communicate properly with the N4421BH67, configuring the PNA from a 2-port instrument into a 4-port system.

NOTE Option 550 must be installed on the PNA for use with the H67 in 4-Port mode.

1. Select **System > Configure > 4-Port Capability** on the PNA. Refer to [Figure 9](#).

Figure 9 4-Port Capability Enabled



2. Insure that **Restart as 4-Port PNA using this Test Set** is selected. If not, select it and press **OK**. The PNA application will restart. Refer to [Figure 10](#).

Figure 10 2-to-4 Port Restart



3. After the PNA has restarted, verify that the PNA is operating in 4-port mode by selecting **Trace > Measure**. You should see references to Port 4 in the measurement list, such as S41, S42, etc. as shown in [Figure 11](#).

Figure 11 Checking for 4-Port Capability



4. Select **Channel > External Testset > Other**. Refer to [Figure 12](#).

Figure 12 Controlling the External Test Set

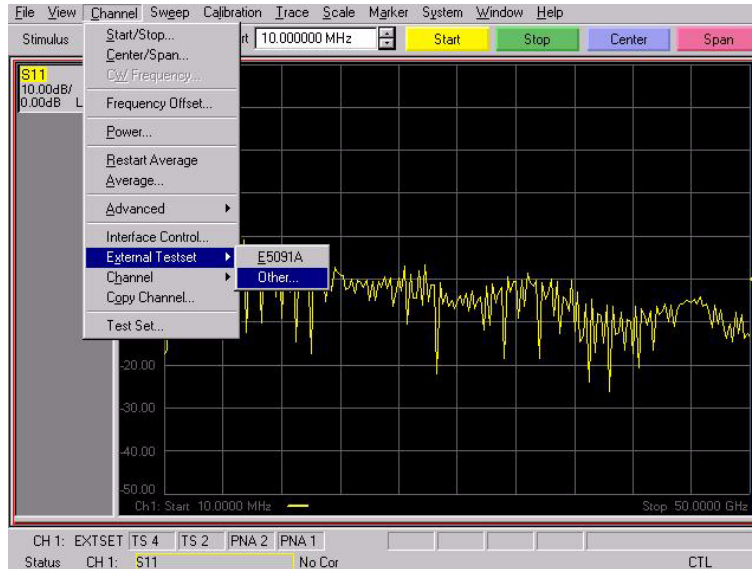

5. The PNA and the N4421BH67 is now configured as a 4-Port system. The **Port Control drop-down menu** allows the user to specify which port of the PNA and Test Set is designated in of the 4-Port System. The default is shown in Port Control and the Test Set properties are displayed on the PNA and are enabled by **Show Test Set Properties**, see [Figure 13](#).

Figure 13 Port Mapping

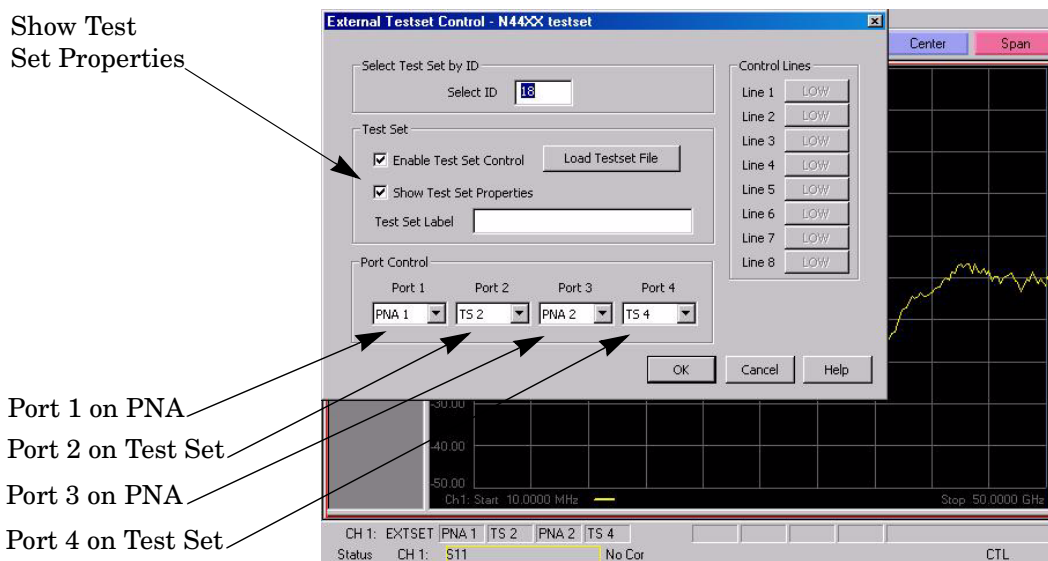

Specification

Specifications for the N4421BH67 Multiport Test Set are typical. System performance for the PNA and Test Set are not provided. A functional certificate is offered for the N4421BH67 only.

NOTE Typical specifications are based on 1 to 2 unit's performance.

Table 6 Operational Verification Limit for Reflection Tracking¹

Frequency	dB
10 MHz to 2 GHz	-23
2 GHz to 10 GHz	-27
10 GHz to 20 GHz	-31
20 GHz to 30 GHz	-36
30 GHz to 40 GHz	-41
40 GHz to 50 GHz	-47
50 GHz to 60 GHz	-48
60 GHz to 67 GHz	-50

1. Reflection Tracking takes into account Source Loss, Receiver Loss, Margin, and PNA Mixer Cal.

NOTE It is recommended that you return your instrument to Agilent Technologies for servicing or repair if the Test Set and PNA performance exceed the operational verification limits.

Operator Check and Performance Verification

Overview

This section provides the test calibration procedure to confirm the N4421BH67 and PNA operational performance. The test limits provided ensure that your N4421BH67 and PNA are operating properly.

The [Agilent Technologies N4421B Option H67](#) requires that the user be familiar with the equipment and components listed in [Table 7](#). The sequence of this procedure is very important and must be followed or the performance accuracy and results may vary from the reference plots provided.

Equipment Required

This section provides an Equipment List and setup of the PNA and PNA Test Set.

Table 7 Equipment List

Description	Qty
E8361A Network analyzer 10 MHz to 67 GHz (with firmware 6.0)	1
N4694A ECal module or 85058B/E Cal Kit (or equivalent)	1
N4697E/F 1.85 mm RF (f-f) cable, 28 inch minimum or equivalent	1
1.8 mm male short (or equivalent)	1
GPIB Cable 0.5 meter (or equivalent)	1
RF long PNA/TS jumper cables (N4421-20009)	4
RF short PNA/TS jumper cables (N4421-20010)	4

Procedure

1. Connect the Test Set to the PNA using jumpers N4421-20009 and N4421-20010 as shown in [Figure 14](#). Refer to [Table 5](#) on page 12.

Figure 14 Test Set to PNA Connections

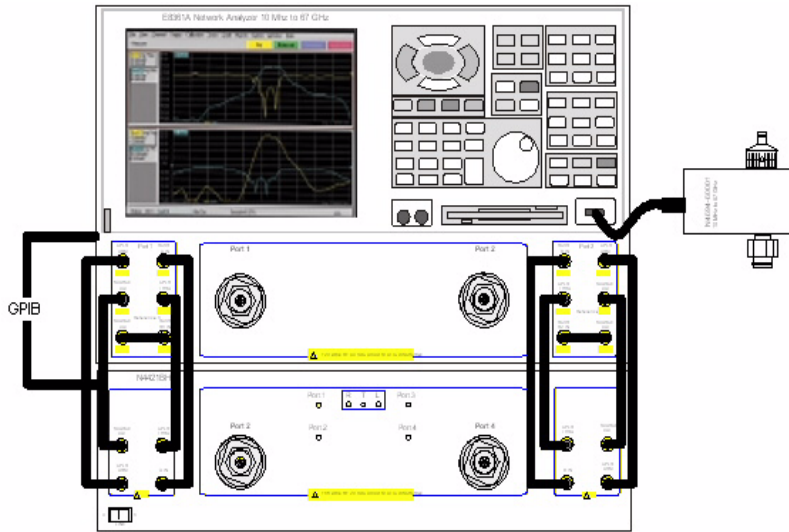

2. Connect the ECal module to the PNA's USB port. Refer to [Figure 14](#) on page 19.
3. Configure the PNA as indicated in [Table 8](#).

Table 8 PNA Initial Setup

Start Frequency:	10 MHz
Stop Frequency:	67 GHz
Power Level:	-17 dBm
IF Bandwidth:	100
Number of Points:	401
System Configure:	4-Port Capability

4. Once the ECal module, Test Set and PNA have been ON for a minimum of a 30 minutes, proceed to the next section.

5. Perform a 1-Port Calibration using the Ecal for Port 1. Refer to [Figure 15](#).

Figure 15 1-Port Calibration

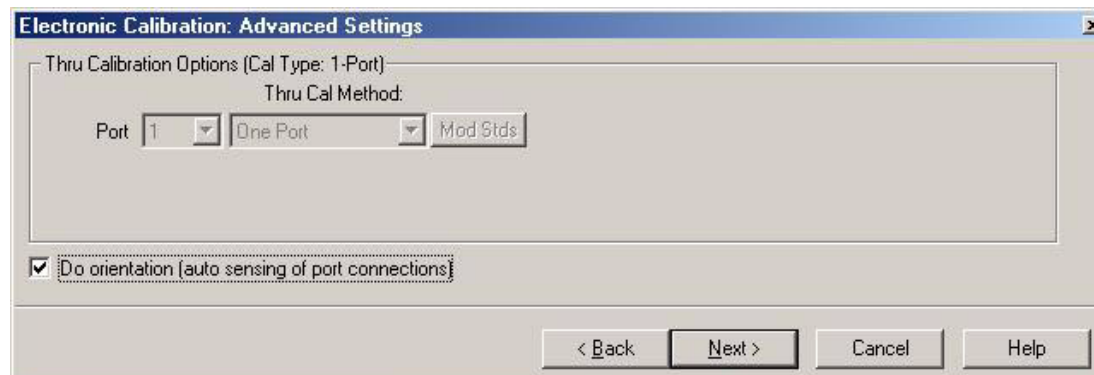
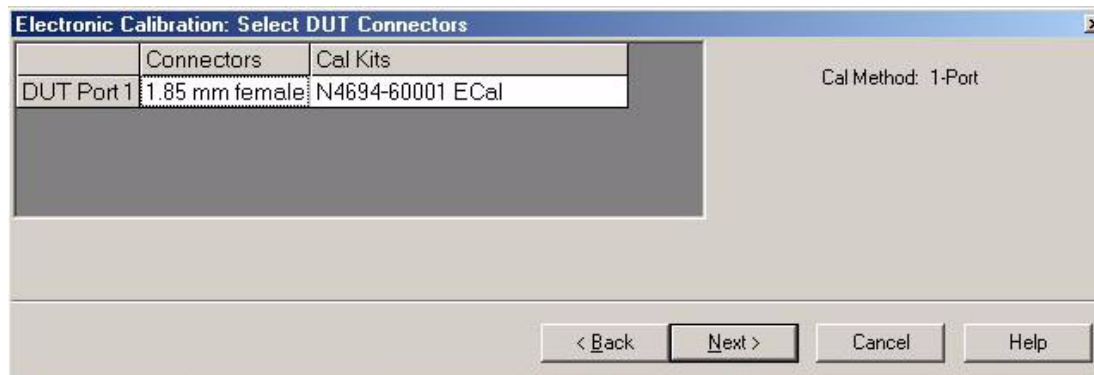
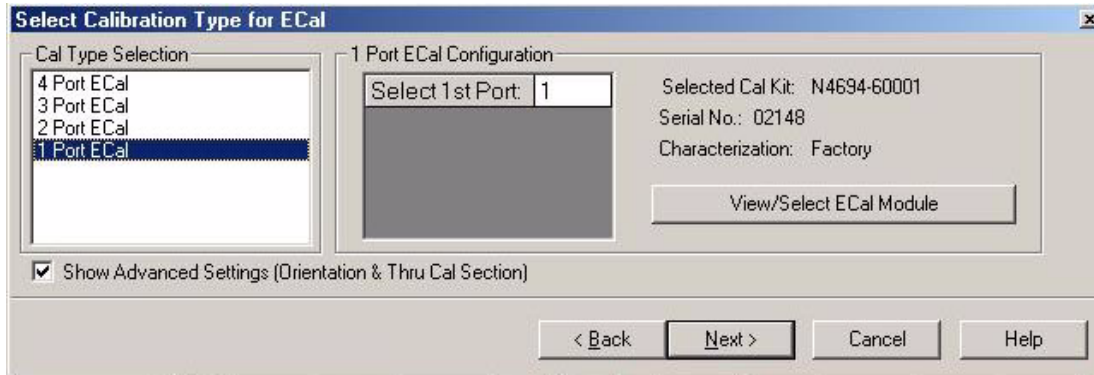

6. The instructions will prompt the user to connect the Ecal as shown in [Figure 16](#).

Figure 16 Ecal at Port 1

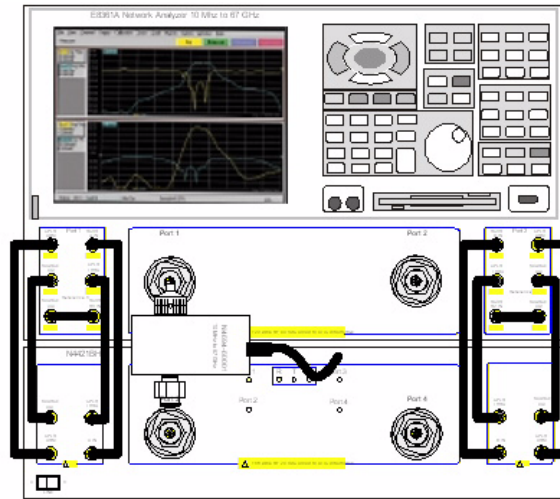

7. Complete the calibration by selecting **Save As User CalSet** using the name **Port1_Cal**.

Figure 17 Calibration Complete

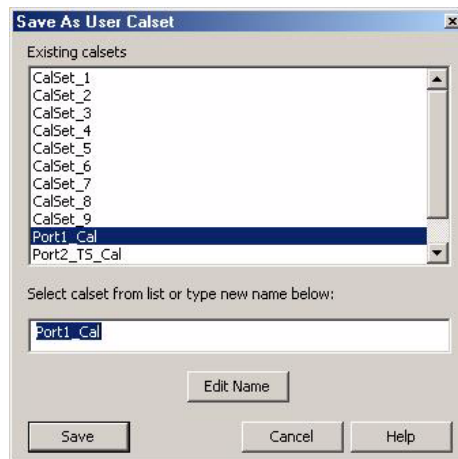
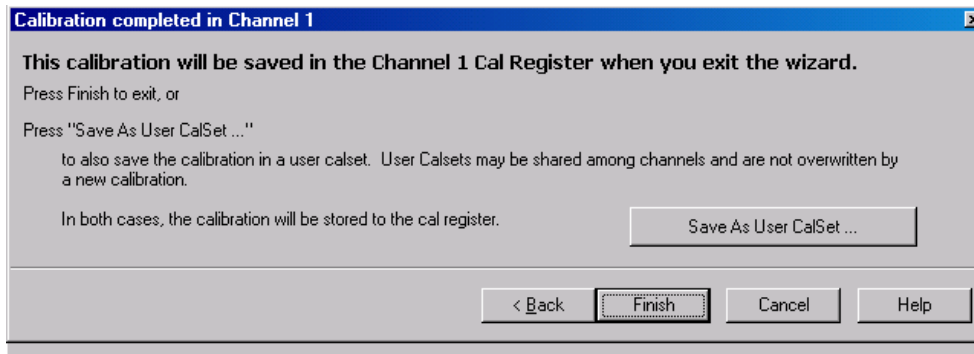

8. Perform a 1-Port calibration using the Ecal for Port 2. Refer to [Figure 15 on page 20](#).
9. The instructions will prompt the user to connect the Ecal as shown in [Figure 18](#).

Figure 18 Ecal at Port 2

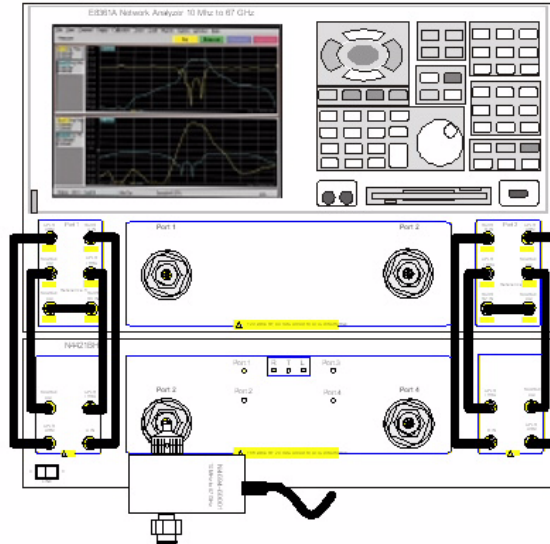

10. Complete the calibration by selecting **Save As User CalSet** using the name **Port2_TS_Cal**. Refer to [Figure 17 on page 21](#).
11. Perform a 1-Port Calibration using the Ecal for Port 3. Refer to [Figure 15 on page 20](#).
12. The instructions will prompt the user to connect the Ecal as shown in [Figure 19](#).

Figure 19 Ecal at Port 3

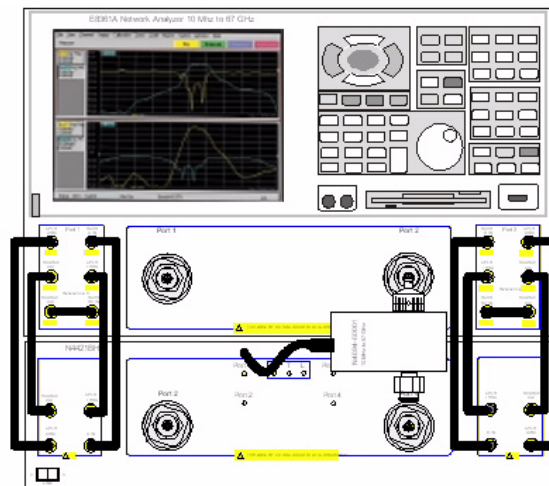

13. Complete the calibration by selecting **Save As User CalSet** using the name **Port3_Cal**. Refer to [Figure 17 on page 21](#).

14. Perform a 1-Port calibration using the Ecal for Port 4. Refer to [Figure 15 on page 20](#).
15. The instructions will prompt the user to connect the Ecal as shown in [Figure 20](#).

Figure 20 Ecal at Port 4

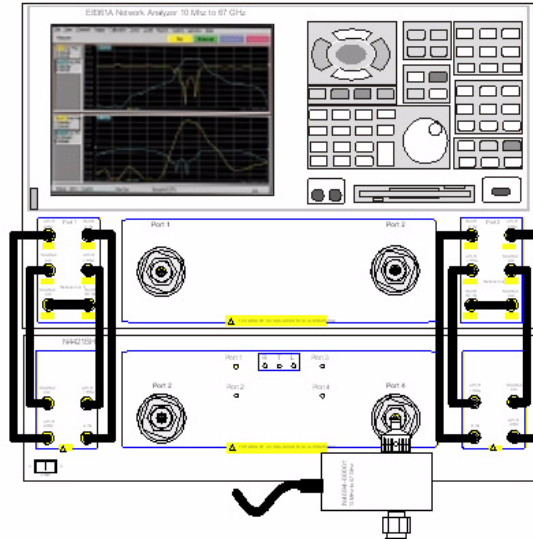

16. Complete the calibration by selecting **Save As User CalSet** using the name **Port4_TS_Cal**. Refer to [Figure 17 on page 21](#).
17. When the 1-Port calibration is complete, select **Cal Set Viewer** in the drop-down menu, as shown in [Figure 21](#).

Figure 21 Calibration, Cal Set Viewer

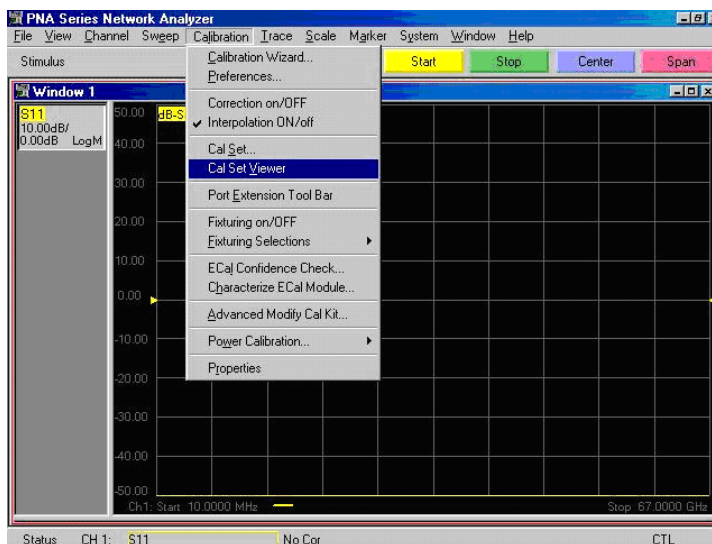

- From the Cal Sets drop-down menu, select **Port1_Cal**. Select the **Reflection Tracking(1,1)** term in the center drop-down menu and ensure that the Enable and Error Terms are selected as shown in [Figure 22](#). This is the Port 1 source and receiver loss.

Figure 22 Port 1 SRC and RCVR Loss



- From the Cal Sets drop-down menu, select **Port2_TS_Cal**. Select the **Reflection Tracking(2,2)** term in the center drop-down menu as shown in [Figure 23](#). This is the Port 2 source and receiver loss.

Figure 23 Port 2 SRC and RCVR Loss



- From the Cal Sets drop-down menu, select **Port3_Cal**. Select the **Reflection Tracking(3,3)** term in the center drop-down menu as shown in [Figure 24](#). This is the Port 3 source and receiver loss.

Figure 24 Port 3 SRC and RCVR Loss



- From the Cal Sets drop-down menu, select **Port4_TS_Cal**. Select the **Reflection Tracking(4,4)** term in the center drop-down menu as shown in [Figure 25](#). This is the Port 4 source and receiver loss.

Figure 25 Port 4 SRC and RCVR Loss



22. Verify that the data has passed as shown in Figure 26. Refer to Table 6, “Operational Verification Limit for Reflection Tracking,” on page 17.

Figure 26 Limits

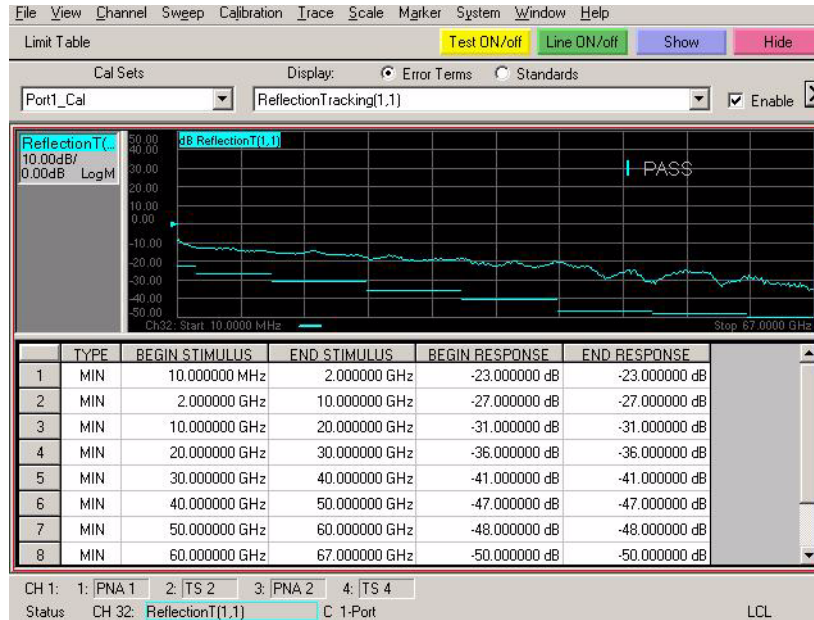

Declaration of Conformity

For a copy of the manufacturer’s Declaration of Conformity for this apparatus, contact your local Agilent Technologies office or sales representative on “[Contacting Agilent Sales and Service Offices](#)” on page 35.

Block Diagram

Figure 27 Block Diagram for the N4421BH67

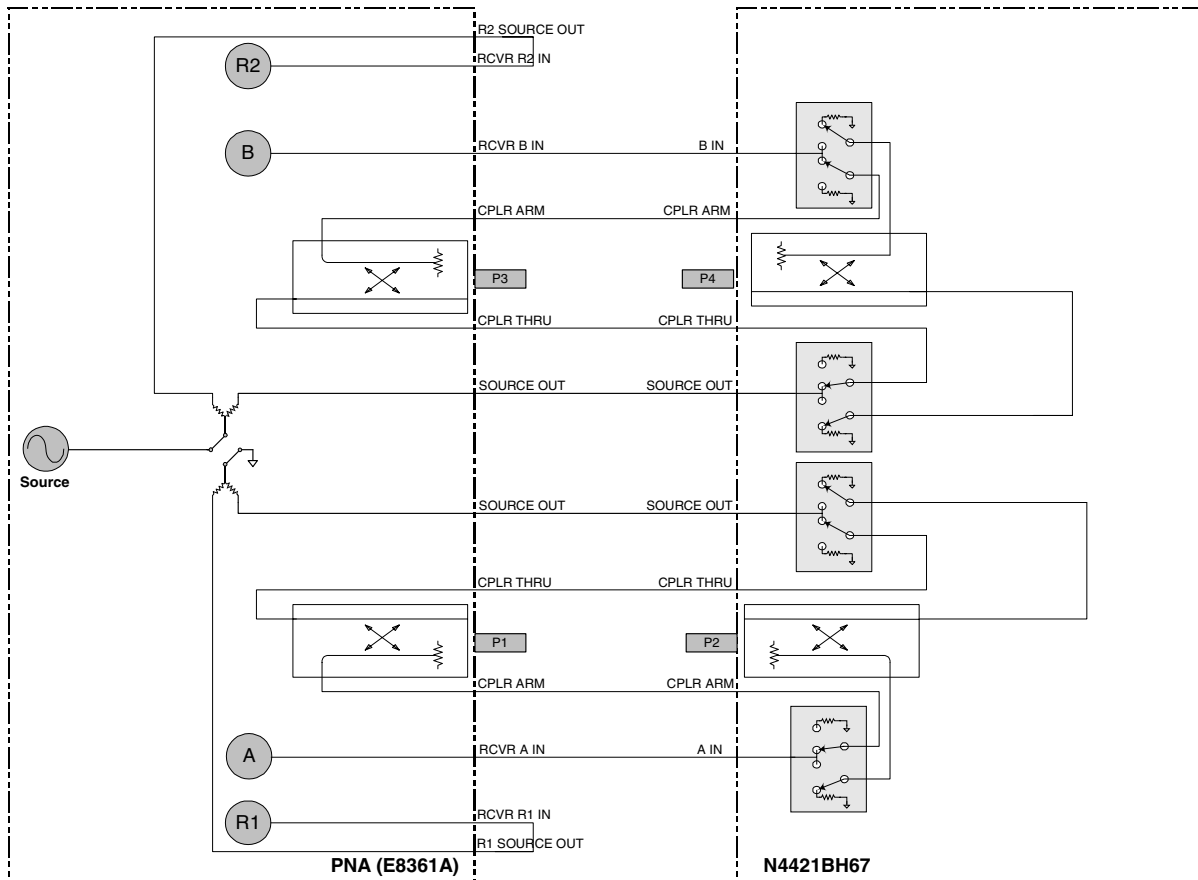

Servicing the N4421BH67 Multiport Test Set

Replaceable Parts

Table 9 Replaceable Parts for the N4421BH67

Description	Agilent Part Number	Qty
Power Supply	0950-3491	1
OEM GPIB Interface board	1150-7952	1
Bulkhead Connector, 1.85 mm (f)	5065-4673	8
Coupler 1.85MM	5087-7225	2
Microcircuit 67GHz switch	5087-7317	4
Semi - Rigid Cable	N4421-20001	1
Semi - Rigid Cable	N4421-20002	1
Semi - Rigid Cable	N4421-20003	1
Semi - Rigid Cable	N4421-20004	1
Semi - Rigid Cable	N4421-20005	2
Semi - Rigid Cable	N4421-20006	2
Semi - Rigid Cable	N4421-20007	2
Semi - Rigid Cable	N4421-20008	2
Semi - Rigid Cable	N4421-20009	4
Semi - Rigid Cable	N4421-20010	4
Switch Control board	N4421-63011	1
ALC AMP power cable 18in - 4 POSN to 4 POSN, twisted pair	Z5623-60048	4

Return to Agilent Technologies factory for servicing or repair. Refer to [“Contacting Agilent Sales and Service Offices”](#) on page 35.

WARNING No operator serviceable parts inside. Refer servicing to qualified personnel. To prevent electrical shock do not remove covers.

WARNING These servicing instructions are for use by qualified personnel only. To avoid electrical shock, do not perform any servicing unless you are qualified to do so.

Shipping Instructions

You must always call the Agilent Technologies Instrument Support Center to initiate service before retuning your instrument to a service office. See [“Contacting Agilent Sales and Service Offices” on page 35](#). Always transport or ship the instrument using the original packaging if possible. If not, comparable packaging must be used to ensure that the front panel connectors are properly protected so that no damage occurs. Attach a complete description of the failure symptoms.

Safety and Regulatory Information

Introduction

Review this product and related documentation to familiarize yourself with safety markings and instructions before you operate the instrument. This product has been designed and tested in accordance with international standards.

Before Applying Power

Verify that the product is configured to match the available main power source. If this product is to be powered by autotransformer, make sure the common terminal is connected to the neutral (grounded) side of the ac power supply.

Connector Care and Cleaning

If alcohol is used to clean the connectors, the power cord to the instrument must be removed. All cleaning should take place in a well ventilated area. Allow adequate time for the fumes to disperse and moist alcohol to evaporate prior to energizing the instrument.

WARNING **To prevent electrical shock, disconnect the Agilent Technologies model N4421B from mains before cleaning. Use a dry cloth or one slightly dampened with water to clean the external case parts. Do not attempt to clean internally.**

Compliance with Canadian EMC Requirements

This ISM device complies with Canadian ICES-001.
Cet appareil ISM est conforme a la norme NMB du Canada.

Complies with European EMC Directive 89/336/EEC, amended by 93/68/EEC

- IEC/EN 61326
- CISPR Pub 11 Group 1, class A
- AS/NZS 2064
- ICES/NMB-001

Complies with European Low Voltage Directive 73/23/EEC, amended by 93/68/EEC

- IEC/EN 61010
- Canada: CSA C22.2 No. 61010
- USA: UL 61010B

Compliance with German Noise Requirements

This is to declare that this instrument is in conformance with the German Regulation on Noise Declaration for Machines (Laermangabe nach der Maschinenlaermverordnung-3. GSGV Deutschland).

Acoustic Noise Emission/Geraeuschemission	
LpA<70 dB	Lpa<70 dB
Operator Position	am Arbeitsplatz
Normal Operation	normaler Betrieb
per ISO 7779	nach DIN 45635 t. 19

Warnings

WARNING **The WARNING notice denotes a hazard. It calls attention to a procedure, practice, or the like, which if not correctly performed or adhered to, could result in personal injury. Do not proceed beyond a WARNING notice until the indicated conditions are fully understood and met.**

Warnings applicable to this instrument are:

WARNING **For continued protection against fire hazard replace line fuse only with same type and rating:**

- **United States—F 2.5A/250V, Part Number 2110-1334**
- **Europe—F 2.5A/250V, Part Number 2110-1334**

The use of other fuses or material is prohibited.

WARNING **This is a Safety Class I product (provided with a protective earthing ground incorporated in the power cord). The mains plug shall be inserted only into a socket outlet provided with a protective earth contact. Any interruption of the protective conductor, inside or outside the instrument, is likely to make the instrument dangerous. Intentional interruption is prohibited.**

WARNING **The power cord is connected to internal capacitors that may retain dangerous electrical charges for 5 seconds after disconnecting the plug from its power supply.**

WARNING **The opening of covers or removal of parts is likely to expose dangerous voltages. Disconnect the instrument from all voltage sources while it is being opened.**

WARNING **If this product is not used as specified, the protection provided by the equipment could be impaired. This product must be used in a normal condition (in which all means for protection are intact) only.**

WARNING **The detachable power cord is the instrument disconnecting device. It disconnects the mains circuits from the mains supply before other parts of the instrument. The front panel switch is only a standby switch and is not a LINE switch (disconnecting device).**

Cautions

CAUTION The CAUTION notice denotes a hazard. It calls attention to an operating procedure, practice, or the like, which if not correctly performed or adhered to, could result in damage to the product or loss of important data. Do not proceed beyond a CAUTION notice until the indicated conditions are fully understood and met.

Cautions applicable to this instrument are:









CAUTION Always use the three-prong ac power cord supplied with this instrument. Failure to ensure adequate earth grounding (by not using this cord) can cause instrument damage.

CAUTION This instrument has autoranging line voltage input; be sure the supply voltage is within the specified range.

CAUTION Ventilation Requirements: When installing the instrument in a cabinet, the convection into and out of the instrument must not be restricted. The ambient temperature (outside the cabinet) must be less than the maximum operating temperature of the instrument by 4 °C for every 100 watts dissipated in the cabinet. If the total power dissipated in the cabinet is greater than 800 watts, forced convection must be used.

CAUTION This product is designed for use in Installation Category II and Pollution Degree 2 per IEC 61010-1:2000, and 664 respectively.

Instrument Markings

	When you see this symbol on your instrument, you should refer to the instrument's instruction manual for important information.
	This symbol indicates hazardous voltages.
	The laser radiation symbol is marked on products that have a laser output.
	This symbol indicates that the instrument requires alternating current (ac) input.
	The CE mark is a registered trademark of the European Community. If it is accompanied by a year, it indicates the year the design was proven.
	The CSA mark is a registered trademark of the Canadian Standards Association.
	This symbol indicates the product meets the Australian Standards.
	This symbol indicates separate collection for electrical and electronic equipment, mandated under EU law as of August 13, 2005. All electric and electronic equipment are required to be separated from normal waste for disposal (Reference WEEE Directive, 2002/96/EC).
	This text indicates that the instrument is an Industrial Scientific and Medical Group 1 Class A product (CISPR 11, Clause 4).
	This symbol indicates that the power line switch is ON.
	This symbol indicates that the power line switch is OFF or in STANDBY position.
	Safety Earth Ground. This is a Safety Class I product (provided with a protective earthing terminal). An uninterruptible safety earth ground must be provided from the main power source to the product input wiring terminals, power cord, or supplied power cord set. Whenever it is likely that the protection has been impaired, the product must be made inoperative and secured against any unintended operation.

Contacting Agilent Sales and Service Offices

Assistance with test and measurement needs, and information on finding a local Agilent office are available on the Internet at:

<http://www.agilent.com/find/assist>

You can also purchase accessories or documentation items on the Internet at:

<http://www.agilent.com/find>

If you do not have access to the Internet, contact your field engineer.

NOTE In any correspondence or telephone conversation, refer to the product by its model number and full serial number. With this information, the Agilent representative can determine whether your unit is still within its warranty period.
